

General purpose JFET quad operational amplifiers

Datasheet — production data

Features

- Wide common-mode (up to V_{CC^+}) and differential voltage range
- Low input bias and offset current
- Output short-circuit protection
- High input impedance JFET input stage
- Internal frequency compensation
- Latch up free operation
- High slew rate: 16 V/ μ s (typical)

Description

The TL084I, TL084AI, TL084BI, TL084C, TL084AC and TL084BC are high-speed, JFET input, quad operational amplifiers incorporating well matched, high voltage JFET and bipolar transistors in a monolithic integrated circuit.

The devices feature high slew rates, low input bias and offset currents, and low offset voltage temperature coefficient.

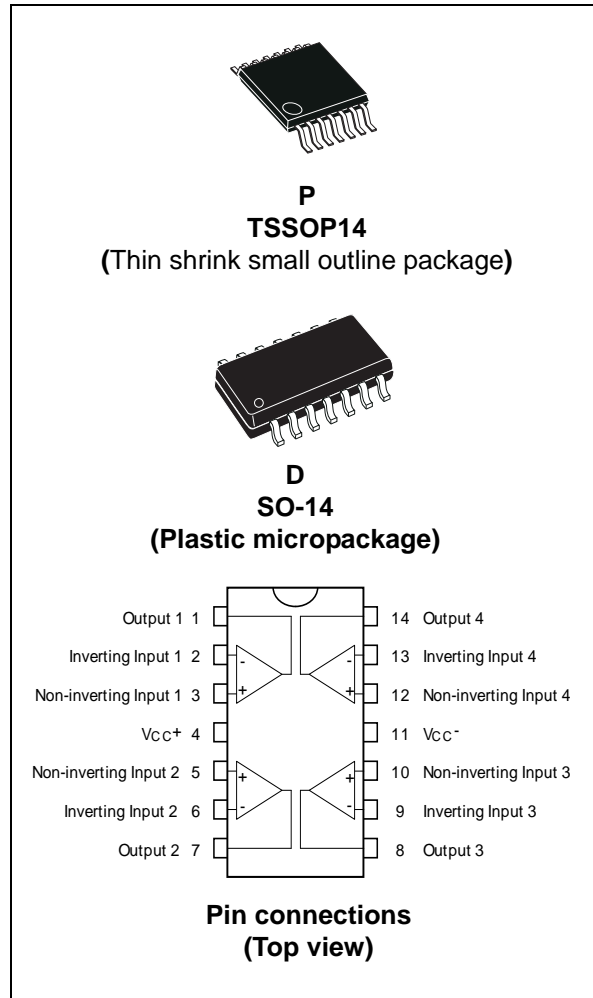

Contents

1	Schematic diagram	3
2	Absolute maximum ratings and operating conditions	4
3	Electrical characteristics	5
4	Parameter measurement information	10
5	Typical applications	11
6	Package information	13
	6.1 TSSOP14 package information	13
	6.2 SO-14 package information	14
7	Ordering information	15
8	Revision history	16

1 Schematic diagram

Figure 1. Circuit schematics (for each amplifier)

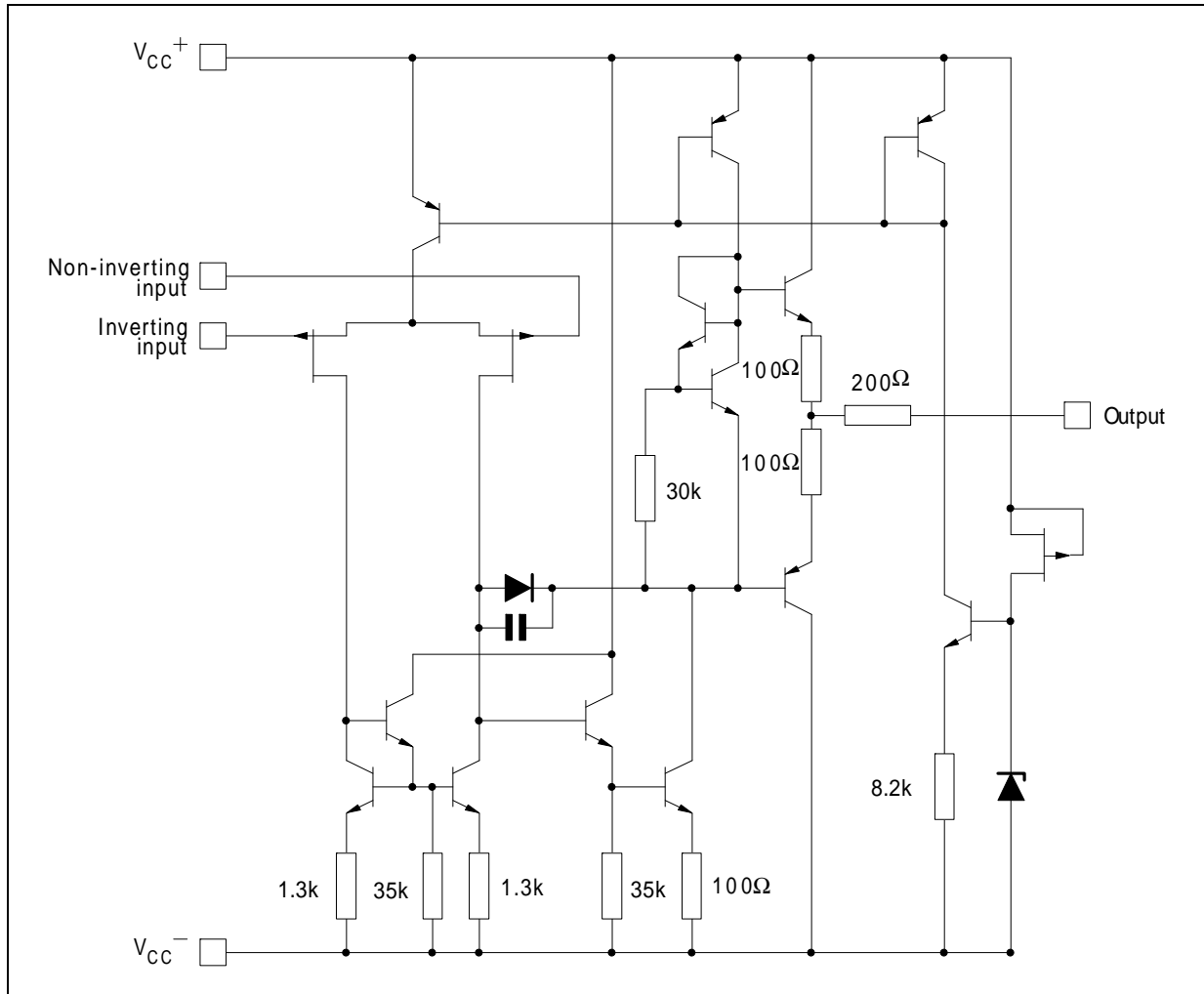

2 Absolute maximum ratings and operating conditions

Table 1. Absolute maximum ratings

Symbol	Parameter	Value	Unit
V_{CC}	Supply voltage ⁽¹⁾	±18	V
V_{in}	Input voltage ⁽²⁾	±15	
V_{id}	Differential input voltage ⁽³⁾	±30	
R_{thja}	Thermal resistance junction to ambient ⁽⁴⁾⁽⁵⁾ TSSOP14 SO-14	100 105	°C/W
P_{tot}	Power dissipation	680	mW
	Output short-circuit duration ⁽⁶⁾	Infinite	
T_{oper}	Operating free-air temperature range: for TL084I/TL084AI/TL084BI	-40 to +125	°C
	Operating free-air temperature range: for TL084C/TL084AC/TL084BC	0 to +70	
T_{stg}	Storage temperature range	-65 to +150	
ESD	HBM: human body model ⁽⁷⁾	1000	V
	MM: machine model ⁽⁸⁾	150	
	CDM: charged device model ⁽⁹⁾	1500	

1. All voltage values, except differential voltage, are with respect to the zero reference level (ground) of the supply voltages where the zero reference level is the midpoint between V_{CC}^+ and V_{CC}^- .
2. The magnitude of the input voltage must never exceed the magnitude of the supply voltage or 15 volts, whichever is less.
3. Differential voltages are the non-inverting input terminal with respect to the inverting input terminal.
4. Short-circuits can cause excessive heating and destructive dissipation.
5. R_{th} are typical values.
6. The output may be shorted to ground or to either supply. Temperature and/or supply voltages must be limited to ensure that the dissipation rating is not exceeded.
7. Human body model: 100 pF discharged through a 1.5 kΩ resistor between two pins of the device, done for all couples of pin combinations with other pins floating.
8. Machine model: a 200 pF cap is charged to the specified voltage, then discharged directly between two pins of the device with no external series resistor (internal resistor < 5 Ω), done for all couples of pin combinations with other pins floating.
9. Charged device model: all pins plus package are charged together to the specified voltage and then discharged directly to the ground.

Table 2. Operating conditions

Symbol	Parameter	TL084I/AI/BI	TL084C/AC/BC	Unit
V_{CC}	Supply voltage range	6 to 36		V
T_{oper}	Operating free-air temperature range	-40 to +125	0 to +70	°C

3 Electrical characteristics

Table 3. $V_{CC} = \pm 15\text{ V}$, $T_{amb} = +25\text{ }^\circ\text{C}$ (unless otherwise specified)

Symbol	Parameter	TL084I/AI/AC/BI/BC			TL084C			Unit
		Min.	Typ.	Max.	Min.	Typ.	Max.	
V_{io}	Input offset voltage ($R_S = 50\ \Omega$)							mV
	$T_{amb} = +25\text{ }^\circ\text{C}$ TL084		3	10		3	10	
	$T_{amb} = +25\text{ }^\circ\text{C}$ TL084A		3	6				
	$T_{amb} = +25\text{ }^\circ\text{C}$ TL084B		1	3				
	$T_{min} \leq T_{amb} \leq T_{max}$ TL084			13			13	
	$T_{min} \leq T_{amb} \leq T_{max}$ TL084A			7				
$T_{min} \leq T_{amb} \leq T_{max}$ TL084B			5					
$\Delta V_{io}/\Delta T$	Input offset voltage drift		10			10		$\mu\text{V}/^\circ\text{C}$
I_{io}	Input offset current							pA nA
	$T_{amb} = +25\text{ }^\circ\text{C}$ $T_{min} \leq T_{amb} \leq T_{max}$		5	100 4		5	100 4	
I_{ib}	Input bias current ⁽¹⁾							pA nA
	$T_{amb} = +25\text{ }^\circ\text{C}$ $T_{min} \leq T_{amb} \leq T_{max}$		20	200 20		30	200 20	
A_{vd}	Large signal voltage gain ($R_L = 2\text{ k}\Omega$, $V_O = \pm 10\text{ V}$)							V/mV
	$T_{amb} = +25\text{ }^\circ\text{C}$ $T_{min} \leq T_{amb} \leq T_{max}$	50 25	200		25 15	200		
SVR	Supply voltage rejection ratio ($R_S = 50\ \Omega$)							dB
	$T_{amb} = +25\text{ }^\circ\text{C}$ $T_{min} \leq T_{amb} \leq T_{max}$	80 80	86		70 70	86		
I_{CC}	Supply current, no load							mA
	$T_{amb} = +25\text{ }^\circ\text{C}$ $T_{min} \leq T_{amb} \leq T_{max}$		1.4	2.5 2.5		1.4	2.5 2.5	
V_{icm}	Input common mode voltage range	± 11	+15 -12		± 11	+15 -12		V
CMR	Common mode rejection ratio ($R_S = 50\ \Omega$)							dB
	$T_{amb} = +25\text{ }^\circ\text{C}$ $T_{min} \leq T_{amb} \leq T_{max}$	80 80	86		70 70	86		
I_{os}	Output short-circuit current							mA
	$T_{amb} = +25\text{ }^\circ\text{C}$ $T_{min} \leq T_{amb} \leq T_{max}$	10 10	40	60 60	10 10	40	60 60	
$\pm V_{opp}$	Output voltage swing							V
	$T_{amb} = +25\text{ }^\circ\text{C}$ $R_L = 2\text{ k}\Omega$	10	12		10	12		
	$R_L = 10\text{ k}\Omega$	12	13.5		12	13.5		
	$T_{min} \leq T_{amb} \leq T_{max}$ $R_L = 2\text{ k}\Omega$	10			10			
$R_L = 10\text{ k}\Omega$	12			12				
SR	Slew rate $V_{in} = 10\text{ V}$, $R_L = 2\text{ k}\Omega$, $C_L = 100\text{ pF}$, unity gain	8	16		8	16		V/ μs

Table 3. $V_{CC} = \pm 15\text{ V}$, $T_{amb} = +25\text{ }^\circ\text{C}$ (unless otherwise specified) (continued)

Symbol	Parameter	TL084I/AI/AC/BI/BC			TL084C			Unit
		Min.	Typ.	Max.	Min.	Typ.	Max.	
t_r	Rise time $V_{in} = 20\text{ mV}$, $R_L = 2\text{ k}\Omega$, $C_L = 100\text{ pF}$, unity gain		0.1			0.1		μs
K_{ov}	Overshoot $V_{in} = 20\text{ mV}$, $R_L = 2\text{ k}\Omega$, $C_L = 100\text{ pF}$, unity gain		10			10		%
GBP	Gain bandwidth product $V_{in} = 10\text{ mV}$, $R_L = 2\text{ k}\Omega$, $C_L = 100\text{ pF}$, $F = 100\text{ kHz}$	2.5	4		2.5	4		MHz
R_i	Input resistance		10^{12}			10^{12}		Ω
THD	Total harmonic distortion $F = 1\text{ kHz}$, $R_L = 2\text{ k}\Omega$, $C_L = 100\text{ pF}$, $A_v = 20\text{ dB}$, $V_o = 2\text{ V}_{pp}$)		0.01			0.01		%
e_n	Equivalent input noise voltage $R_S = 100\text{ }\Omega$, $F = 1\text{ kHz}$		15			15		$\frac{nV}{\sqrt{Hz}}$
ϕ_m	Phase margin		45			45		degrees
V_{o1}/V_{o2}	Channel separation $A_v = 100$		120			120		dB

1. The input bias currents are junction leakage currents which approximately double for every 10°C increase in the junction temperature.

Figure 2. Maximum peak-to-peak output voltage vs. frequency ($R_L = 2\text{ k}\Omega$) **Figure 3. Maximum peak-to-peak output voltage vs. frequency ($R_L = 10\text{ k}\Omega$)**

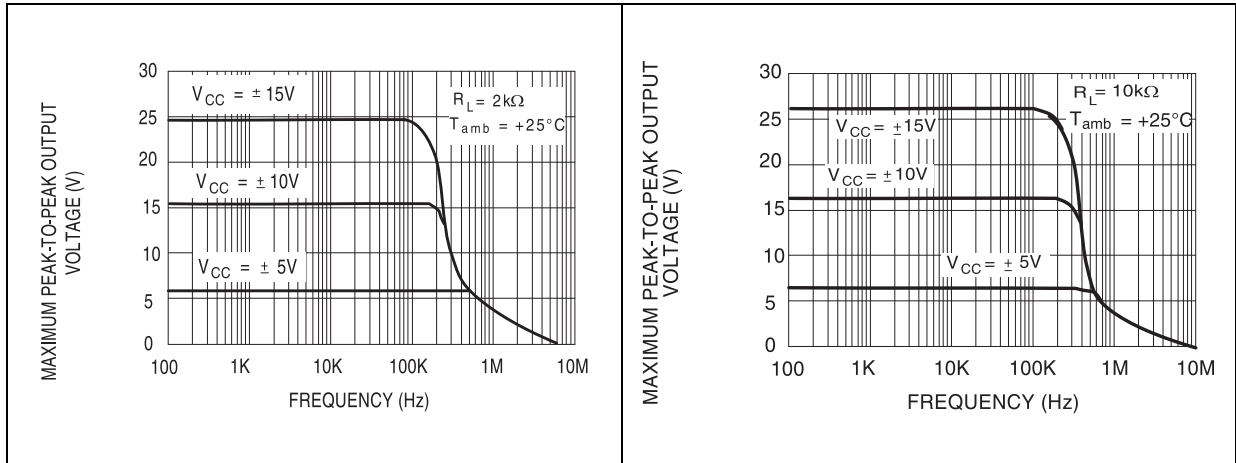

Figure 4. Maximum peak-to-peak output voltage vs. frequency and temp. **Figure 5. Maximum peak-to-peak output voltage vs. free air temp.**

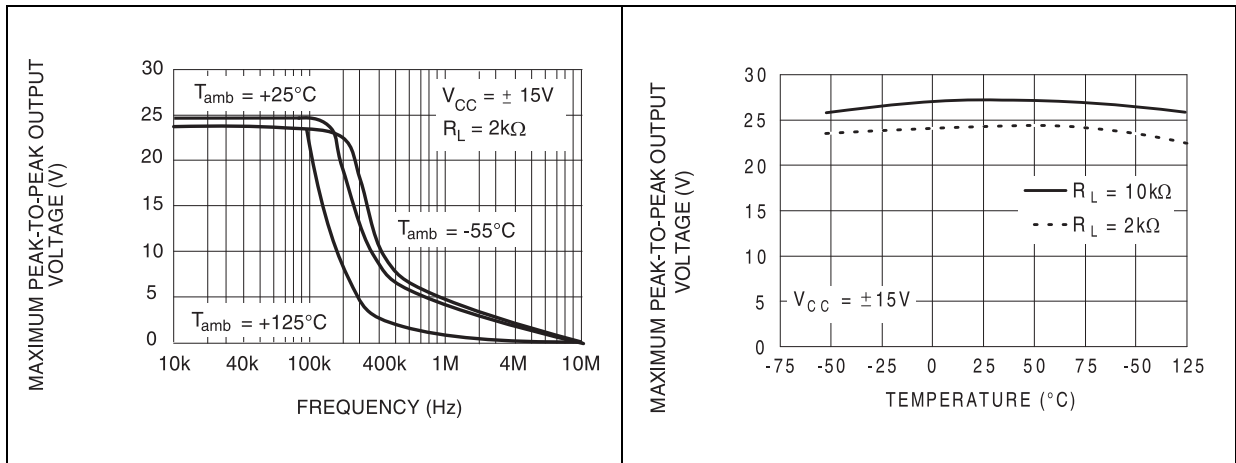

Figure 6. Maximum peak-to-peak output voltage vs. load resistance **Figure 7. Maximum peak-to-peak output voltage vs. supply voltage**

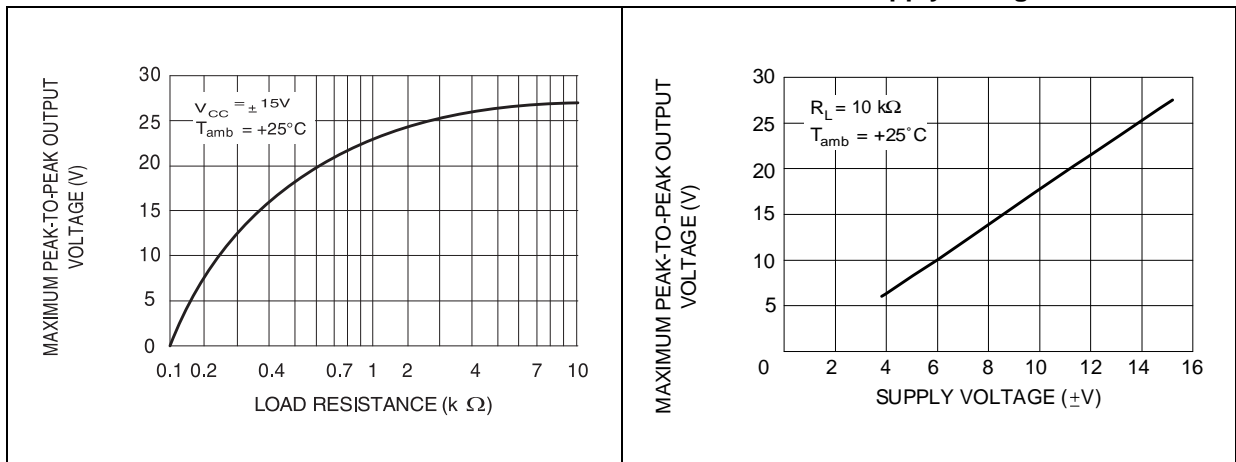

Figure 8. Input bias current vs. free air temp.

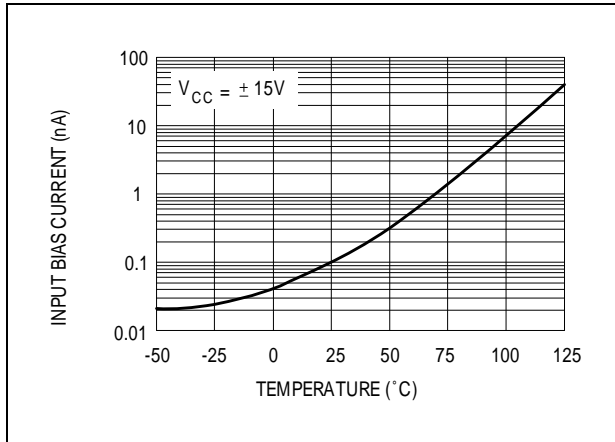

Figure 9. Large signal differential voltage amplification vs. free air temp.

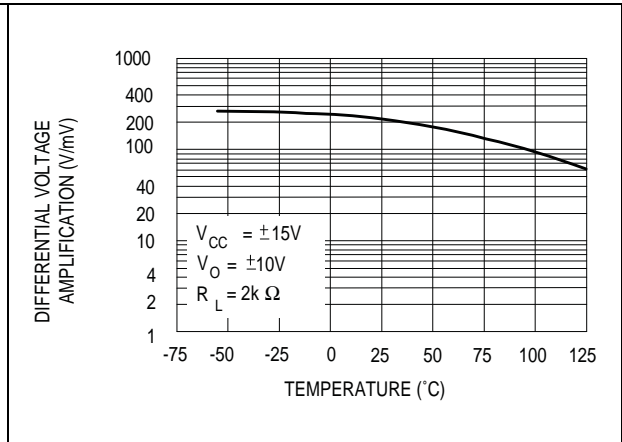

Figure 10. Large signal differential voltage amplification and phase shift vs. frequency

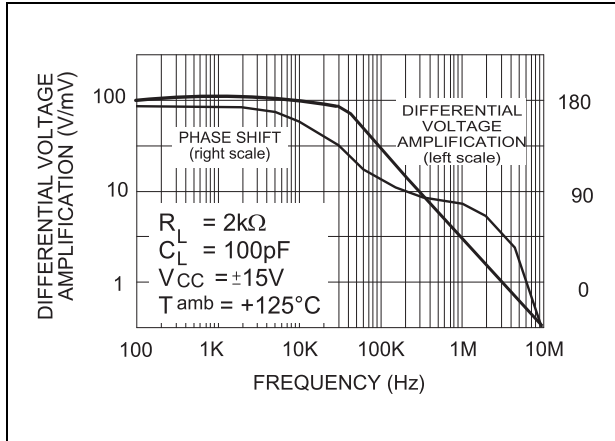

Figure 11. Total power dissipation vs. free air temp.

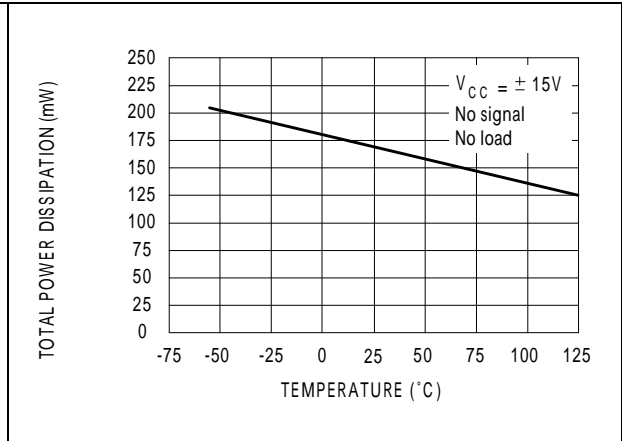

Figure 12. Supply current per amplifier vs. free air temp.

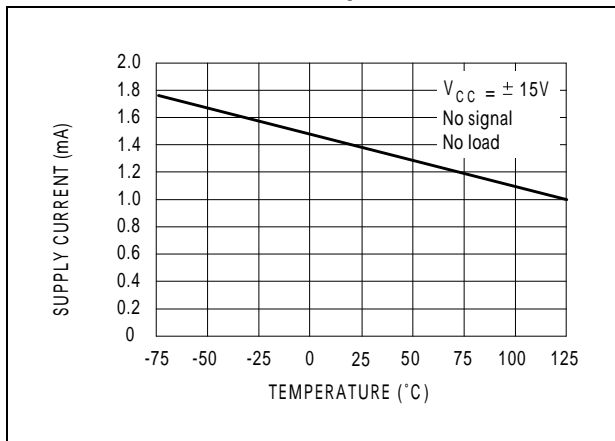

Figure 13. Supply current per amplifier vs. supply voltage

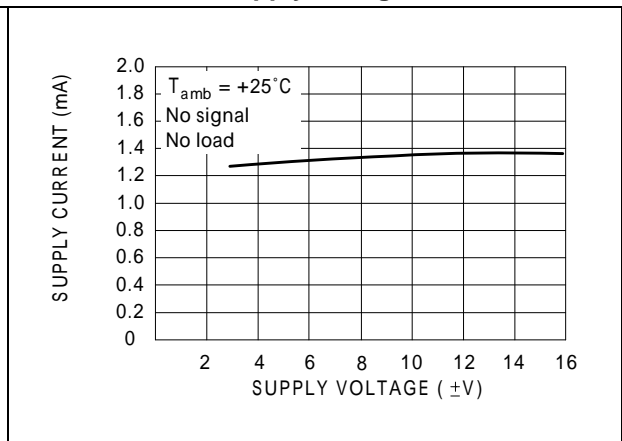

Figure 14. Common mode rejection ratio vs. free air temp.

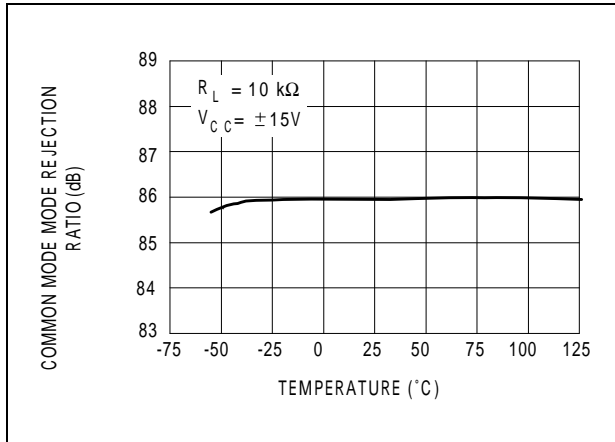

Figure 15. Voltage follower large signal pulse response

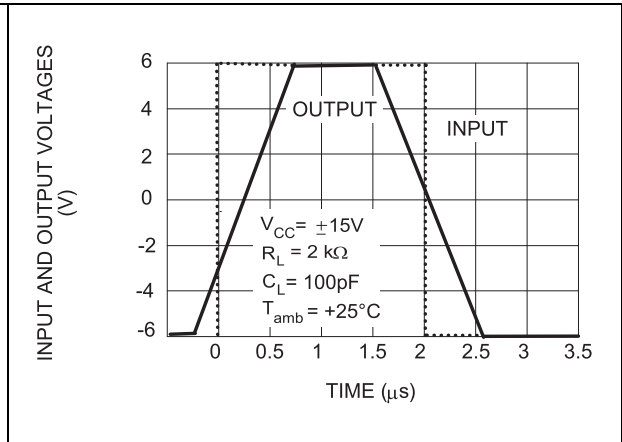

Figure 16. Output voltage vs. elapsed time

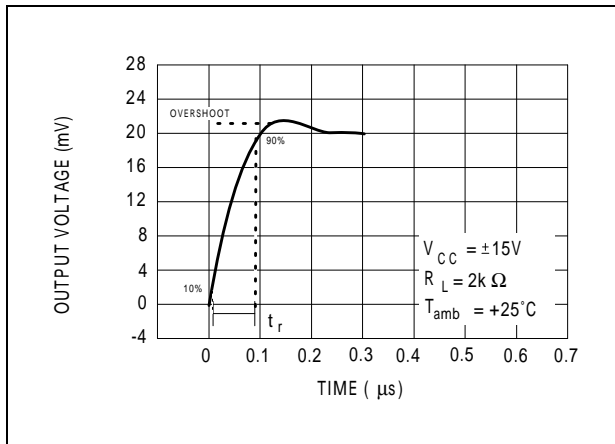

Figure 17. Equivalent input noise voltage vs. frequency

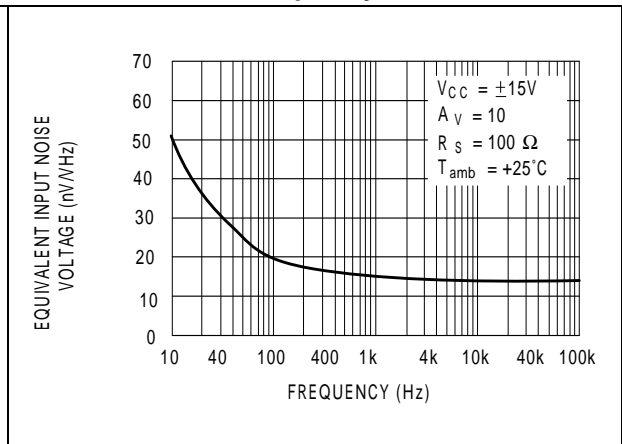
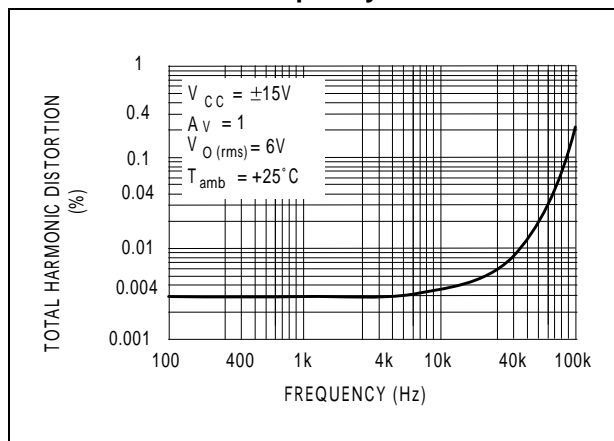

Figure 18. Total harmonic distortion vs. frequency



4 Parameter measurement information

Figure 19. Voltage follower

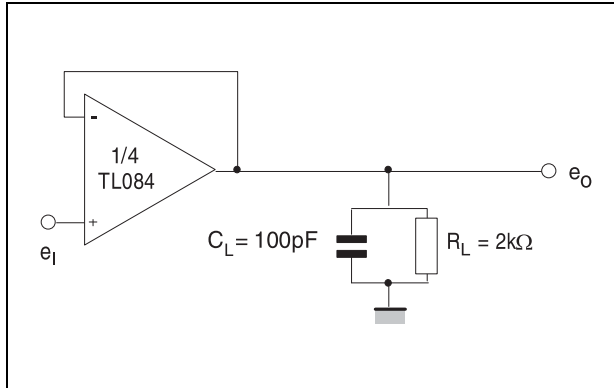
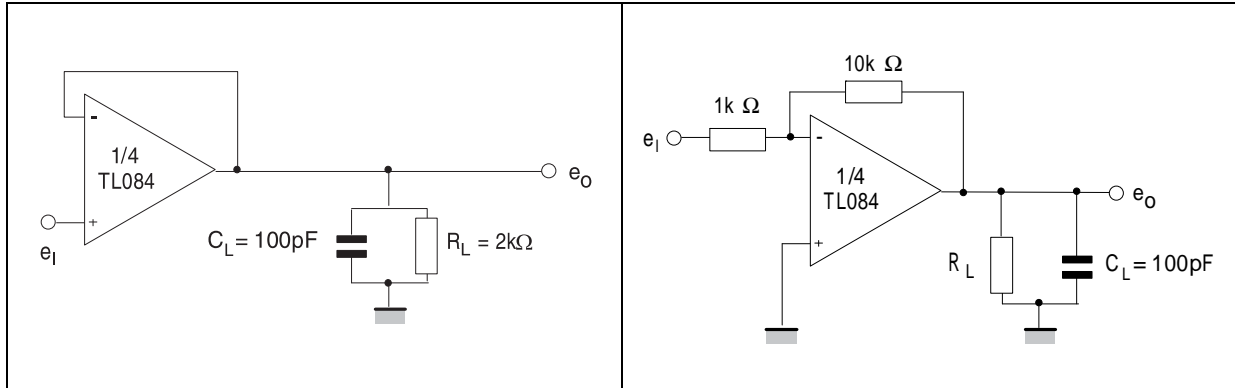

Figure 20. Gain-of-10 inverting amplifier



5 Typical applications

Figure 21. Audio distribution amplifier

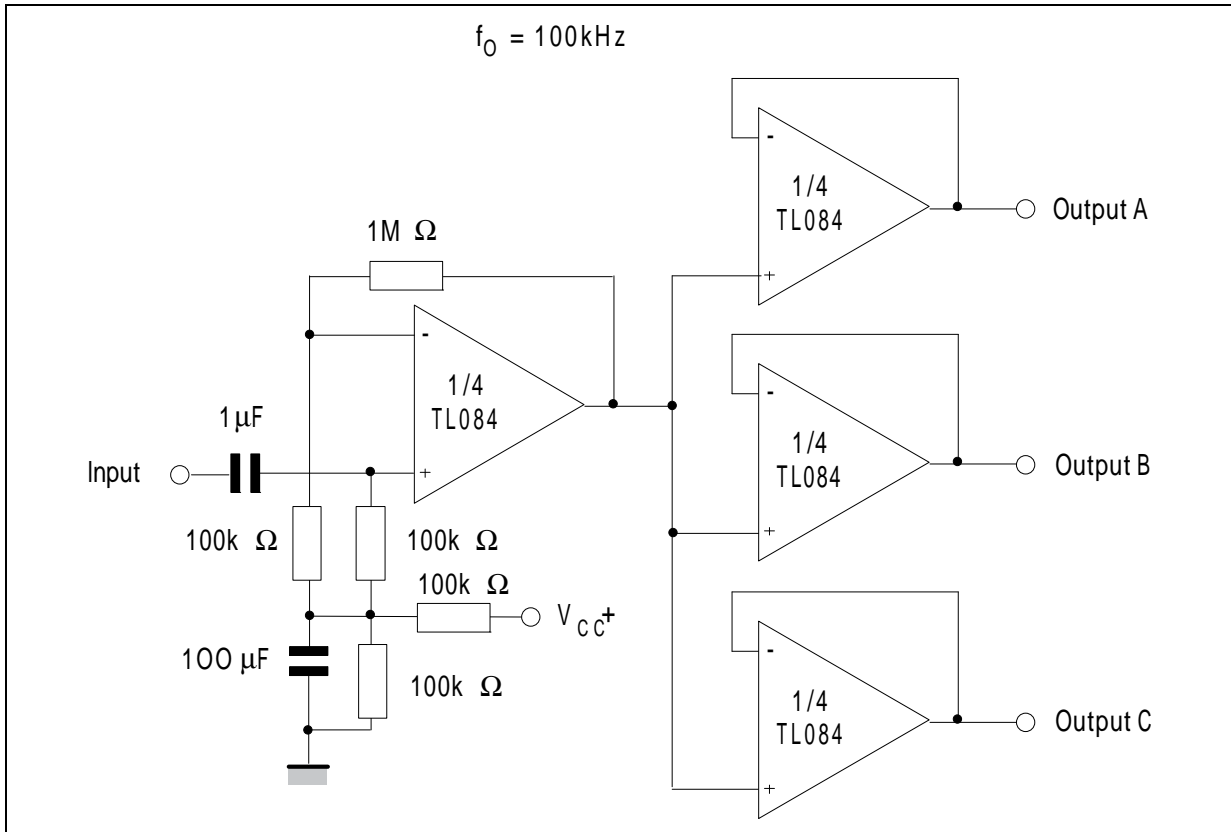

Figure 22. Positive feedback bandpass filter

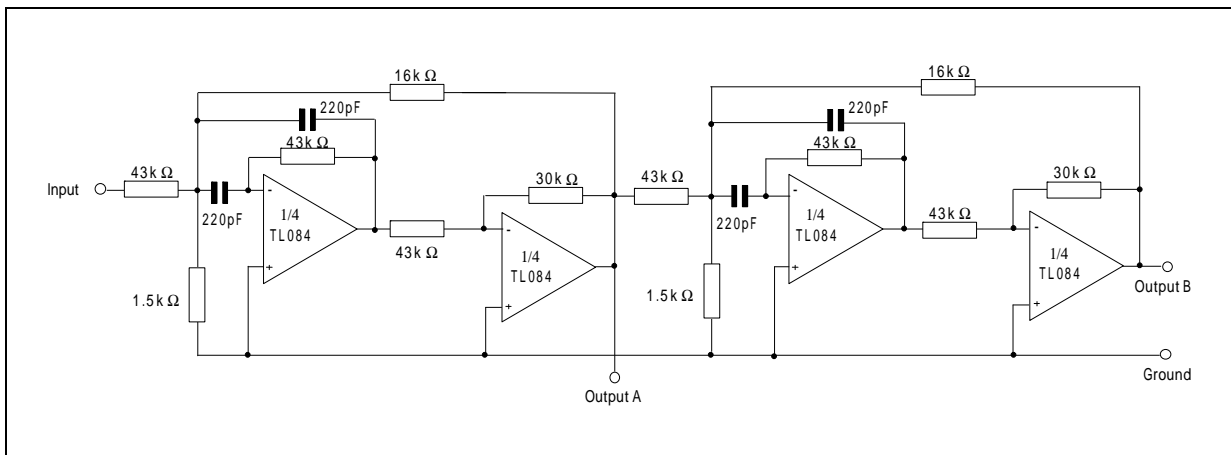
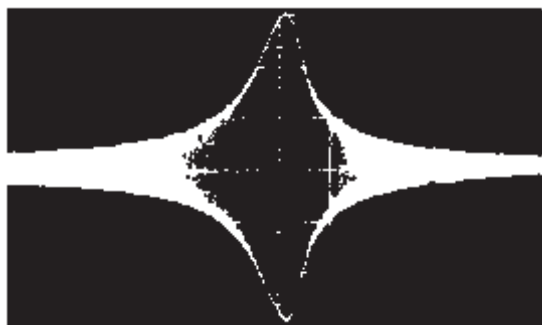
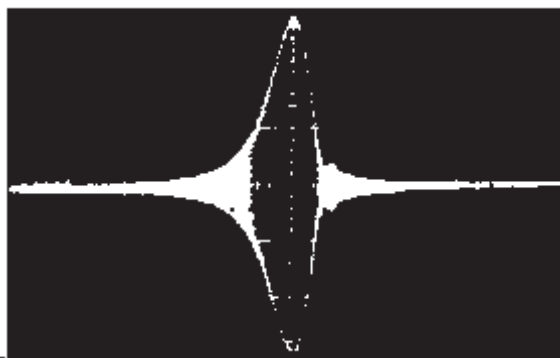

Figure 23. Output A



Second order bandpass filter
fo = 100 kHz; Q = 30; Gain = 4

Figure 24. Output B



Cascaded bandpass filter
fo = 100 kHz; Q = 69; Gain = 16

6 Package information

In order to meet environmental requirements, ST offers these devices in different grades of ECOPACK® packages, depending on their level of environmental compliance. ECOPACK® specifications, grade definitions and product status are available at: www.st.com. ECOPACK® is an ST trademark.

6.1 TSSOP14 package information

Figure 25. TSSOP14 package mechanical drawing

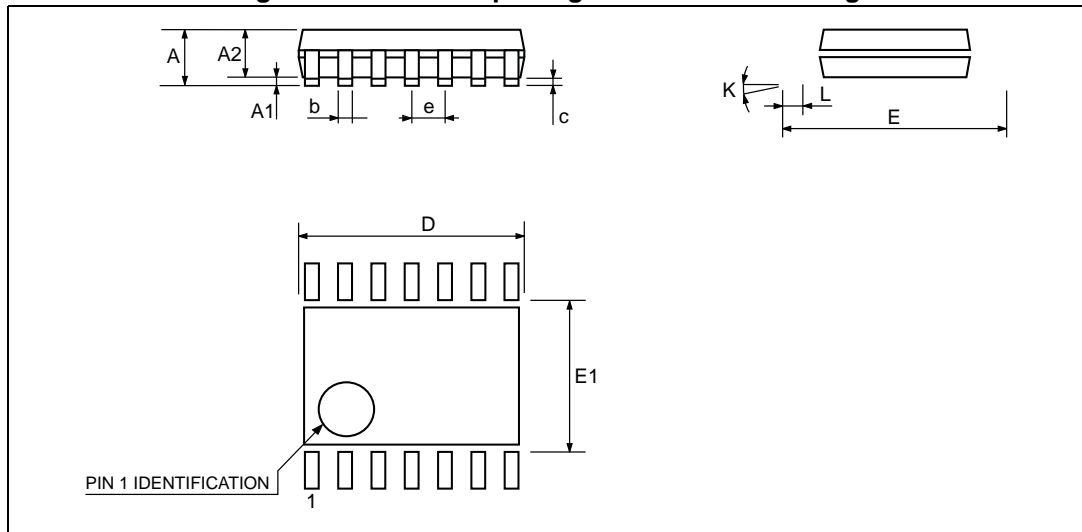

Table 4. TSSOP14 package mechanical data

Ref.	Millimeters			Inches		
	Min.	Typ.	Max.	Min.	Typ.	Max.
A			1.2			0.047
A1	0.05		0.15	0.002	0.004	0.006
A2	0.8	1	1.05	0.031	0.039	0.041
b	0.19		0.30	0.007		0.012
c	0.09		0.20	0.004		0.0089
D	4.9	5	5.1	0.193	0.197	0.201
E	6.2	6.4	6.6	0.244	0.252	0.260
E1	4.3	4.4	4.48	0.169	0.173	0.176
e		0.65 BSC			0.0256 BSC	
K	0°		8°	0°		8°
L1	0.45	0.60	0.75	0.018	0.024	0.030

6.2 SO-14 package information

Figure 26. SO-14 package mechanical drawing

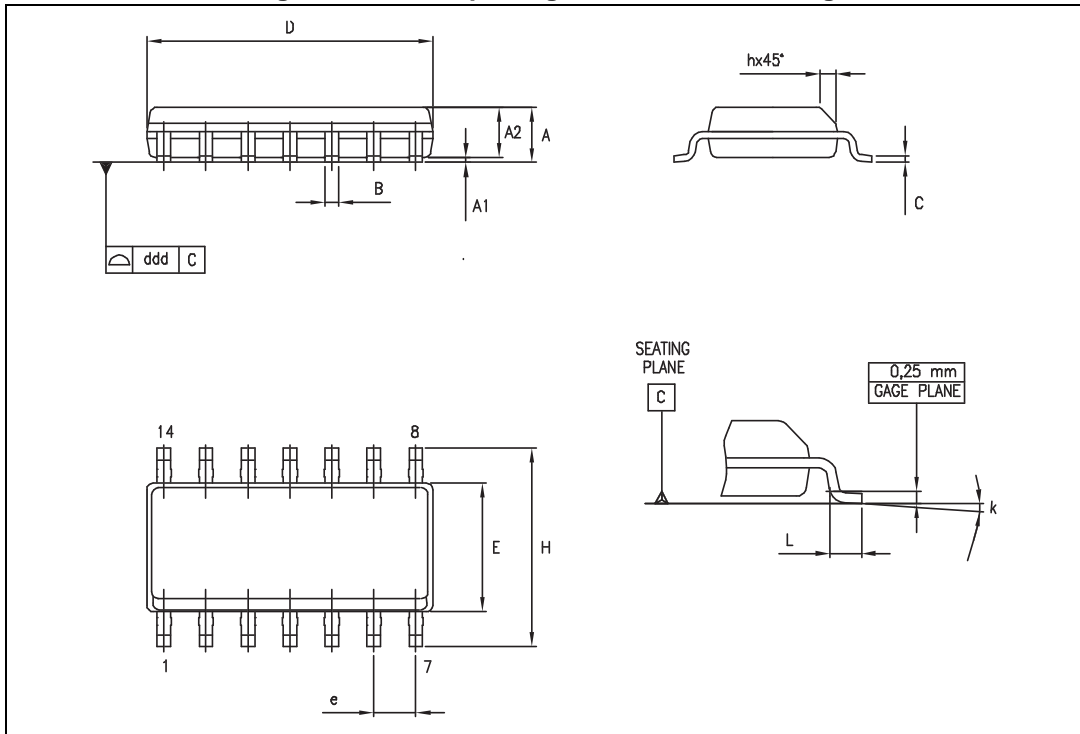

Table 5. SO-14 package mechanical data

Dimensions						
Ref.	Millimeters			Inches		
	Min.	Typ.	Max.	Min.	Typ.	Max.
A	1.35		1.75	0.05		0.068
A1	0.10		0.25	0.004		0.009
A2	1.10		1.65	0.04		0.06
B	0.33		0.51	0.01		0.02
C	0.19		0.25	0.007		0.009
D	8.55		8.75	0.33		0.34
E	3.80		4.0	0.15		0.15
e		1.27			0.05	
H	5.80		6.20	0.22		0.24
h	0.25		0.50	0.009		0.02
L	0.40		1.27	0.015		0.05
k	8° (max.)					
ddd			0.10			0.004

7 Ordering information

Table 6. Order codes

Order code	Temperature range	Package	Packing	Marking
TL084IDT	-40°, +125°	SO-14	Tape & reel	084I
TL084AIDT				084AI
TL084BIDT				084BI
TL084IYDT ⁽¹⁾	SO-14	084IY		
TL084BIYDT ⁽¹⁾		084BIY		
TL084IPT	-40°, +125°	TSSOP14		084I
TL084CDT	0°, +70°	SO-14		084C
TL084ACDT				084AC
TL084BCDT				084BC
TL084CPT		TSSOP14		084C
TL084CD	0°, +70°	SO-14	Tube	084C

1. Qualified and characterized according to AEC Q100 and Q003 or equivalent, advanced screening according to AEC Q001 & Q002 or equivalent.

8 Revision history

Table 7. Document revision history

Date	Revision	Changes
28-Mar-2001	1	Initial release.
30-Jul-2007	2	Added values for R_{thja} , R_{thjc} and ESD in Table 1: Absolute maximum ratings. Added Table 2: Operating conditions. Expanded Table 6: Order codes. Template update.
15-Jul-2008	3	Removed information concerning military temperature ranges (TL084Mx, TL084AMx, TL084BMx). Added automotive grade order codes in Table 6: Order codes.
05-Jul-2012	4	Removed commercial types TL084IYD, TL084AIYD and TL084BIYD. Updated Table 6: Order codes.
29-Jan-2013	5	Added part numbers TL084A and TL084B. Added SO-14 package silhouette. Updated layout of Table 1: Absolute maximum ratings. Updated of Table 3: $V_{CC} = \pm 15\text{ V}$, $T_{amb} = +25\text{ °C}$ (unless otherwise specified). Replaced SO-14 package mechanical drawing (Figure 27: SO-14 package mechanical drawing). Replaced SO-14 package mechanical data (Table 5: SO-14 package mechanical data).
11-Jul-2017	6	Replaced 105 °C by 125 °C in Table 1: Absolute maximum ratings and Table 2: Operating conditions. Removed DIP14 package information. Updated Table 6: Order codes to remove obsolete part numbers.
17-Oct-2017	7	Updated part numbers in the title, and in Table 6: Order codes .

IMPORTANT NOTICE – PLEASE READ CAREFULLY

STMicroelectronics NV and its subsidiaries ("ST") reserve the right to make changes, corrections, enhancements, modifications, and improvements to ST products and/or to this document at any time without notice. Purchasers should obtain the latest relevant information on ST products before placing orders. ST products are sold pursuant to ST's terms and conditions of sale in place at the time of order acknowledgement.

Purchasers are solely responsible for the choice, selection, and use of ST products and ST assumes no liability for application assistance or the design of Purchasers' products.

No license, express or implied, to any intellectual property right is granted by ST herein.

Resale of ST products with provisions different from the information set forth herein shall void any warranty granted by ST for such product.

ST and the ST logo are trademarks of ST. All other product or service names are the property of their respective owners.

Information in this document supersedes and replaces information previously supplied in any prior versions of this document.

© 2017 STMicroelectronics – All rights reserved